

Learning on the move

Hypertag project

THE
FITZWILLIAM
MUSEUM



Learning on the move

18 month project



3 informal learning environments – project partners

Project aim

- to develop interactive mobile multimedia interpretation tools
- based on handheld devices
- understand better how these tools can enhance learning outcomes in informal learning environments.

National Space Centre



UK's largest research and education centre dedicated to the excitement of space

Space now - News and information service

The Fitzwilliam Museum



University of Cambridge's museum of art
Home to collections of works of art and
antiquities of National and International
significance

Wildwalk-At-Bristol



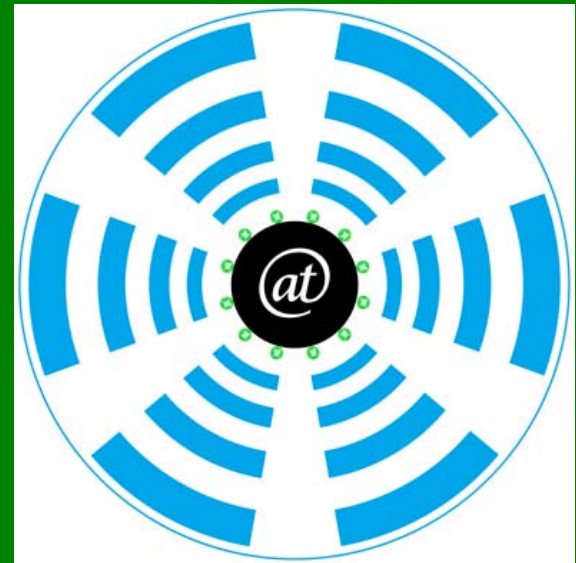

Tags in Venue

Powered Tags emit a continuous Infrared message containing Tag Number

PDA User

User points and clicks on tag. PDA recognises Tag Number and requests the appropriate content from Web server

Wireless Network

Interfaces between the PDA and the Web Server. Sending requests from PDA & returning multimedia content to PDA.

Web Server

Receives requests based on Tag Number and generates appropriate content in real time for display on PDA.

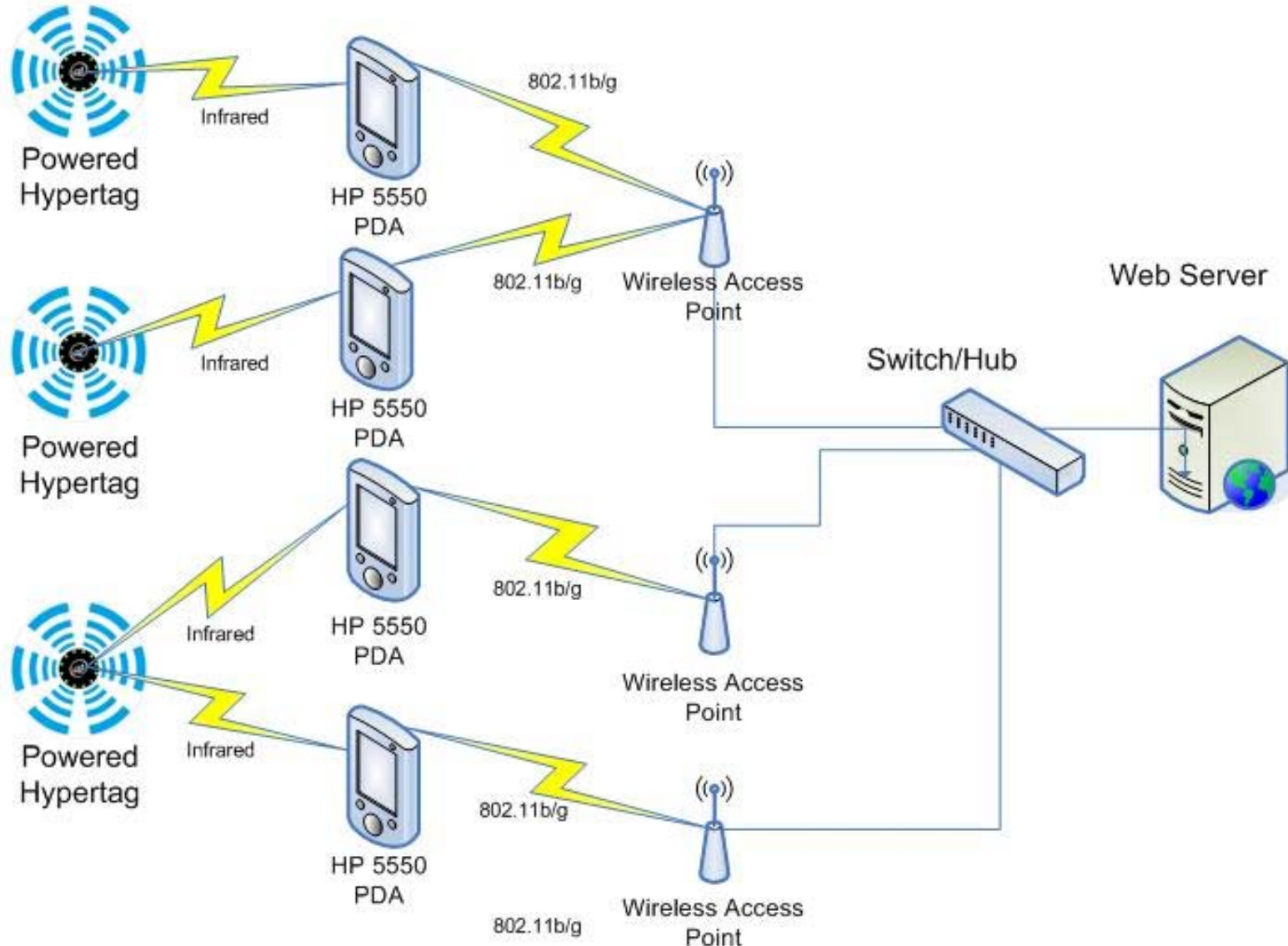

What can this technology offer?

- Genuine interaction and visitor input
- Range of media and content
- Tailoring to visitors' individual needs to improve access
- Pre and Post-visit extension
- Flexible and easy to update content
- Built-in research and evaluation

Content

- Interactive learning games
- Video clips – e.g. meet the keeper
- Audio commentary
- Still images
- Voting system
- Quizzes



READ TAG

HELP



Drag the pictures to complete
the butterfly's lifecycle



Touch to start

main

Database driven - update

Name	Value	Comment
Quiz Info		For each quiz
QuizTitle	Fun fungus quiz	Quiz name, appears in header
RunningTotal	Thank you for taking our quiz. You have got <RIGHT> out of <TOTAL>.	Appears after each question
FinalTotal	You got <RIGHT> out of <TOTAL>.	Appears at end of quiz
Response5	Congratulations, you are a fungus mastermind!	Response to 80-100% correct (at end of quiz)
Response4	Congratulations, you know lots about fungi!	Response to 60-80% correct
Response3	Congratulations, you know lots about fungi!	Response to 40-60% correct
Response2	Well done!	Response to 20-40% correct
Response1	Well done!	Response to 0-20% correct
Question Info		For each question
QuestionNumber	1	
QuestionText	Which of the following foods is made using a fungus?	
CorrectAnswer	1	
Answer1	bread	
Answer2	pasta	
Answer3	chips	
...		You can have up to 10 Answers
Response1	Well done - yeast is a fungus used to make bread rise.	
Response2	Sorry, the correct answer is bread. Yeast is a fungus used to make bread rise.	
Response3	Sorry, the correct answer is bread. Yeast is a fungus used to make bread rise.	
...		You can have up to 10 Responses

Research and evaluation

Evaluation framework for project

- based on five research questions

- Support visitors to consider issues, concepts and connections
- Enable visitors to exercise choice (empowerment)
- Extend exploration of exhibit content (extension)
- Impact on physical experience of galleries
- Operational implications

Recommendations - content

PDA content that works with the object

- promotes personal engagement

Cartoons – simplified line drawings

On-screen transformations

‘Bite size’ commentaries

Range of stimulating content – music, images, video



Recommendations – equipment

Clear location of gallery tags

Chip in handset located for natural pointing

Continuous on-screen navigation bar

Use familiar screen tools - similar to PCs / mobile phones

Concise navigation – minimise clicks!

Problem issues

Avoid too much text / data / commentary

Moving maps can be confusing

User resistance to written instructions

Long latency – speed of PDA response

Sound quality – headphones, hygiene, isolation

Clutter – stylus, earphones, instructions, maps....!

Advice for a successful project

Inter-departmental project team

Experience in web-based education

Apply rigorous content criteria

Support of visitor services staff

– reassurance, training, troubleshooting

Testing, testing, testing!



Find out more.....



At-Bristol <http://www.at-bristol.org.uk>

National Space Centre <http://www.nssc.co.uk/>

The Fitzwilliam Museum <http://www.fitzmuseum.cam.ac.uk/>

NESTA <http://www.nesta.org.uk>

The Royal Institution www.rigb.org

Antenna Audio <http://www.antennaaudio.com/>

Tate Modern <http://www.tate.org.uk/modern/multimediatour/>

Review of digital learning in museums http://www.futurelab.org.uk/research/lit_reviews.htm#lr09

Handheld Learning Forum <http://www.handheldlearning.co.uk/>